

What's New

Trailer Units for High Pressure Cleaners.

We have recently completed the balance of an order of 7 trailer units. They were designed for cleaning contractors in the chicken industry who need to transport all their equipment to many sites. The trailers can carry up to six high pressure cleaners and are fitted with six live hose reels. The centre of the trailer houses a 1000L stainless steel tank. This system is ideal for contract cleaning.



Have you seen our wheels?

We apologise if our deliveries have been a little slow this month, the wheels seem to have fallen off. If anyone has seen them, please contact us.



Meet Our Staff

Ahmed has for many years been a key member of the workshop team. He is responsible for servicing and repairing all equipment. He is Doc's brother but please don't hold this against Doc.



Product in Focus

Mac Valve

The "Mac Valve" is a hydraulic pilot controlled float valve with a difference. It solves most of the typical problems associated with float valves. The most impressive feature of this patented valve is how it allows full flow of incoming water. In normal float valves they activate even if a small amount of water is drained from the tank. This doesn't happen to the Mac Valve, as the shut-off mechanism is such that it is either fully open or fully closed.

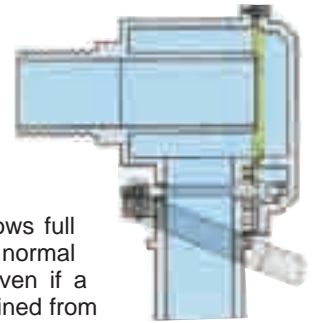

It is made of polycarbonate which makes it very hygienic. It is available in several inlet sizes including 20mm, 25mm, 32mm, 40mm. The outlet in all cases is 25mm.

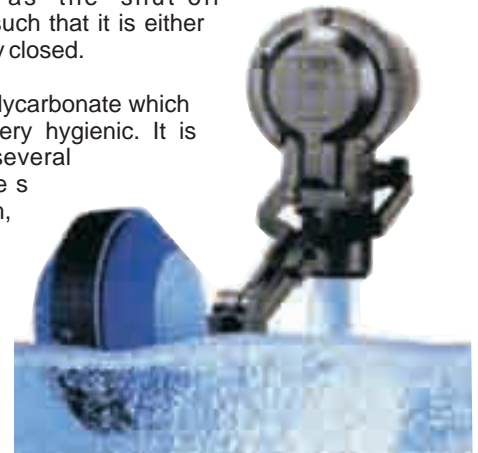

Humour



"Violence is the last refuge of the incompetent"

Versatile, durable and affordable pressure testing solutions



Solve your leaking problems



The Hawk Clean n' Coat Pressure Testing Unit is specially designed to test pipes and tanks at high pressure for any leaks. The unit is connected to one end of the pipe and the other end is blocked. The pipe is then filled with water and pressurised in order to test the pipe. Once the desired pressure is reached the unit is turned off and the gauge monitored. Any drop in pressure would indicate a leak. The models shown in this leaflet reflect the standard Hawk range of pressure testing units. However machines can be custom designed and built to suit just about any application. There are also larger machines available that are capable of pressures up to 500 bar. Petrol units are available.



Technical Data

Model	Pump	L/min	Bar	Kw	Voltage
TE1/11-40	HC190	11	0-40	1,5	220
TE1/11-100	HC190	11	0-100	2,2	220
TE3/11-40	HC190	11	0-40	1,5	380
TE3/11-100	HC190	11	0-100	2,2	380

Unique Guarantee



Precision engineering and the use of high quality materials have enabled Hawk in South Africa to give a comprehensive Guarantee to cover their products. A full one years warranty

covers the workmanship and materials against defects, while they are also covered by a unique spares guarantee. Should the required Hawk pump or accessory spare part not be available within 24 hours because of a out-of-stock situation, they will be airfreighted from the factory, and fitted, free of charge.

Schematic Layout of the Hawk Pressure Tester

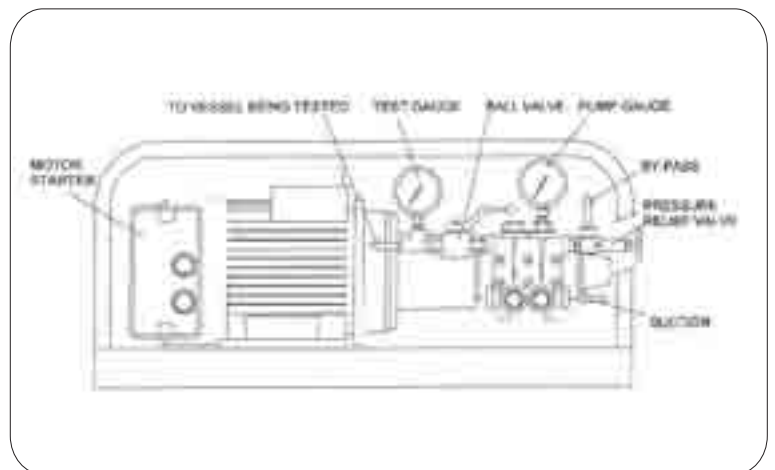

Available From:

Durban (Head Office)
336 Sydney Road Durban, 4000
Phone: (031) 205-4313

Vaal Triangle
15 Loch Street, Meyerton, 1961
Tel: (016) 362-0410

Johannesburg
98 Newton Road, Meadowdale, 1401.
Phone: (011) 974-4662

Port Elizabeth
42 Sidwell Avenue, Port Elizabeth, 6001
Phone: (041) 451-4332

Cape Town
New Street, Durbanville, 7550
Phone: (021) 963-073/4/5